



## Water Truck Fill Point Stand Pipe

Truflo Pumping Systems' water truck fill point stand pipes are engineered to withstand the harsh Australian weather conditions.

Truflo Pumps offer a complete range of water truck fill point stations with sizes ranging from 100mm (4") through to 400mm (16") and water delivery of up to 500L/sec.

Optional full packages include pump, standpipe, interconnection hoses and key fob, which allows the driver to remotely stop and start the system without having to leave the trucks cab. There is also the option of cyclone rating for high wind and cyclone prone areas.

### Applications

Mining	Construction
Ground dewatering	Evaporation projects
Quarries	Sludges & slimes
Pipeline & drilling	Water transfer
Environmental	



# Specifications

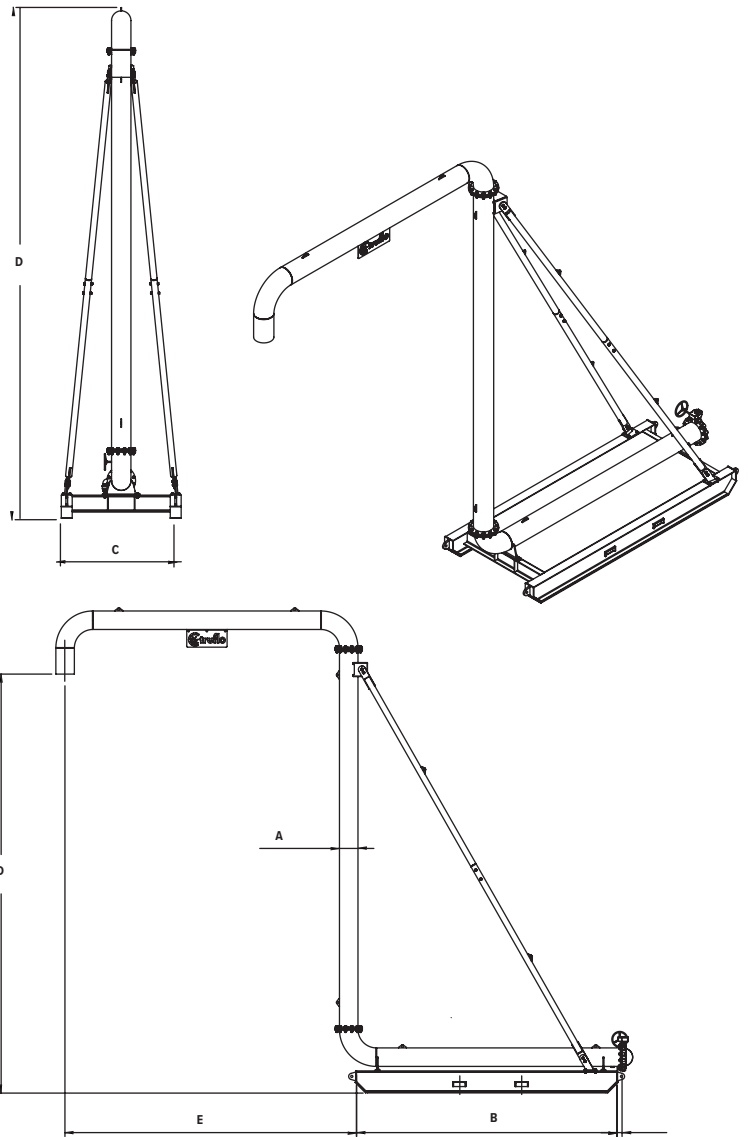

## SPECIFICATIONS

ITEM	DESCRIPTION	A	B	C	D	E
1	150mm (6") Standpipe Assembly	150NB	3000	2200	5000	3825
2	200mm (8") Standpipe Assembly	200NB	3730	2200	5900	4000
3	250mm (10") Standpipe Assembly	250NB	5000	2200	8050	4525
4	300mm (12") Standpipe Assembly	300NB	5000	2200	8050	4750
5	400mm (16") Standpipe Assembly	400NB	5000	2200	8500	4800



FRECALL AUSTRALIA  
**1800 813 677**  
[truflo@truflopumps.com.au](mailto:truflo@truflopumps.com.au)  
[www.truflopumps.com.au](http://www.truflopumps.com.au)

**HEAD OFFICE NSW**  
 8-14 Irving Place, Bathurst NSW 2795  
 Phone +61 2 6333 4500

**SUNSHINE COAST QUEENSLAND**  
 1-3 Industrial Place, Yandina QLD 4561  
 Phone +61 7 5446 7411